

R7008SB

Instruction Manual

FASSTest-2.4GHz Bidirectional Communication System
S.BUS2 / S.BUS Port and 8 Channels for Conventional System Receiver

Usage precaution

- Analog servos cannot be used with the R7008SB in the FASSTest 12CH mode.
- The R7008SB receiver can only be used with FASSTest capable transmitters.
- Don't connect to Extra Voltage before turning on a receiver.

WARNING

- ! Changes or modification not expressly approved by the party responsible for compliance could void the user's authority to operate the equipment.
- ! The R7008SB receiver should be protected from vibration by foam rubber, Velcro or similar mounting methods. Protect from moisture.

- ! Keep away from conductive materials to avoid short circuits.

Antenna installation precaution

- ⊘ Do not cut or bundle the receiver antenna wire.
- ⊘ Do not bend the coaxial cable. It causes damage.
- ! The antennas must be mounted in such a way to assure they are strain relieved.

Compliance Information Statement (for U.S.A.)

This device, trade name Futaba Corporation, model number R7008SB, complies with part 15 of the FCC Rules. Operation is subject to the following two conditions: (1) This device may not cause harmful interference, and (2) This device must accept any interference received, including interference that may cause undesired operation. CAUTION: To assure continued FCC compliance 1. Any changes or modifications not expressly approved by the grantee of this device could void the user's authority to operate the equipment. 2. This equipment complies with FCC radiation exposure limits set forth for an uncontrolled environment. This equipment should be installed and operated with minimum distance 20cm between the radiator & your body. The responsible party of this device compliance is: FUTABA Corporation of America 2681 Wall Triana Hwy Huntsville, AL 35824, U.S.A. Phone:1-256-461-9399 FAX:1-256-461-1059 E-mail: service@futabaUSA.com



Thank you for purchasing a Futaba **R7008SB FASSTest-2.4GHz** compatible receiver. The **R7008SB** receiver features bi-directional communication with a **FASSTest** Futaba transmitter using the **S.BUS2** port. Using the **S.BUS2** port an impressive array of telemetry sensors may be utilized. It also includes both standard PWM output ports and S.BUS output ports.

Applicable systems: Futaba FASSTest-2.4GHz system transmitter

- ! Keep the antenna as far away from the motor, ESC and other noise sources as you possibly can.
- ! Be sure that the two antennas are placed at 90 degrees to each other.
- The R7008SB has two antennas. In order to maximize signal reception and promote safe modeling Futaba has adopted a diversity antenna system. This allows the receiver to obtain RF signals on both antennas and fly problem-free.

Antenna installation for carbon fuselage

WARNING

- ! You must leave 30mm at the tip of the antenna fully exposed. The exposed antenna should be secured so that it cannot move around or back inside of your aircraft.

S.BUS2 precaution

DANGER

- ⊘ Don't connect a connector, as shown in a before figure.
- It will short-circuit, if it connected in this way. A short circuit across the battery terminals may cause abnormal heating, fire and burns.

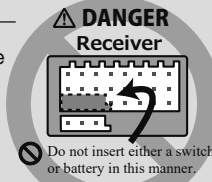

WARNING

- ! Only S.BUS2 capable devices may be connected to the S.BUS2 port. Standard S.BUS servos and gyros should not be connected to the S.BUS2 port.

IC

This device complies with Industry Canada license-exempt RSS standard(s). Operation is subject to the following two conditions: (1) this device may not cause interference, and (2) this device must accept any interference, including interference that may cause undesired operation of the device. This equipment complies with IC radiation exposure limits set forth for an uncontrolled environment. This equipment should be installed and operated with minimum distance 20cm between the radiator and your body.

French

Cet appareil radio est conforme au CNR d'Industrie Canada. L'utilisation de ce dispositif est autorisée seulement aux deux conditions suivantes : (1) il ne doit pas produire de brouillage, et (2) l'utilisateur du dispositif doit être prêt à accepter tout brouillage radioélectrique reçu, même si ce brouillage est susceptible de compromettre le fonctionnement du dispositif. Cet équipement est conforme aux limites d'exposition aux rayonnements IC établies pour un environnement non contrôlé. Cet équipement doit être installé et utilisé avec un minimum de 20 cm de distance entre la source de rayonnement et votre corps.

R7008SB Specifications

FASSTest-2.4GHz system(18CH/12CH mode)/ S.BUS2 and S.BUS port and 8 channels for conventional system receiver

- Dual antenna diversity
- Size: 0.98 x 1.86 x 0.56 in. (24.9 x 47.3 x 14.3 mm)
- Weight: 0.38 oz. (10.9g)
- Power requirement: 3.7V to 7.4V(Voltage range: 3.5 to 8.4V)
- Battery F/S Voltage: It sets up with a transmitter
- Extra Voltage port: 0 ~ 70V DC

* Be sure that when using ESCs regulated output the capacity of the ESC must meet your usage condition.

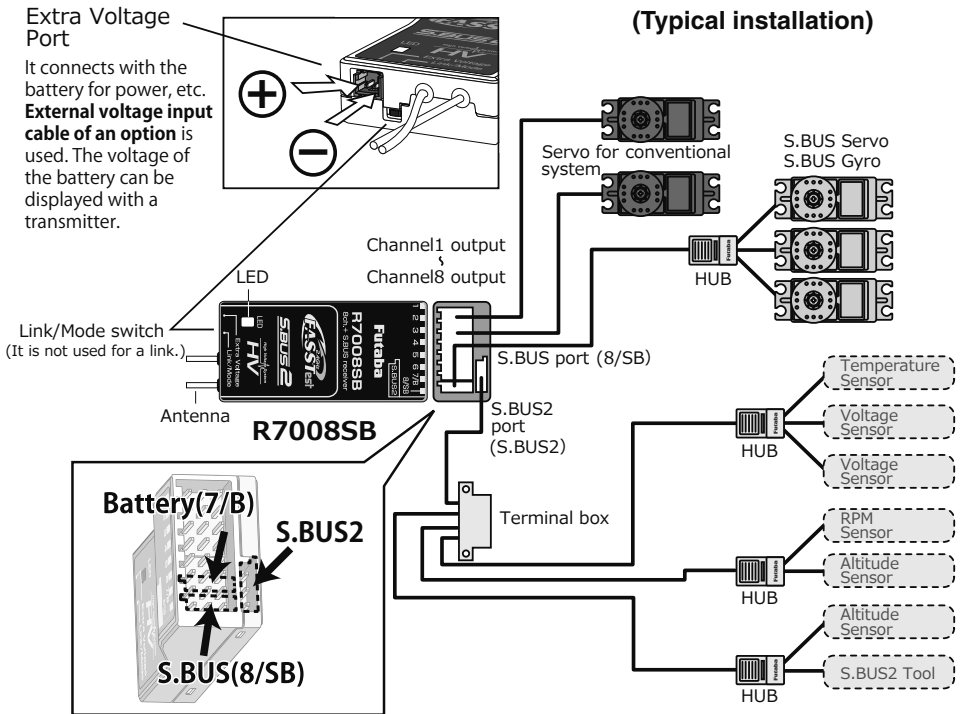

Extra Voltage Port
It connects with the battery for power, etc. **External voltage input cable of an option** is used. The voltage of the battery can be displayed with a transmitter.

(Typical installation)

(Antenna installation)

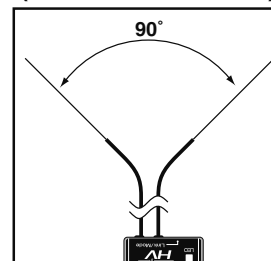

Please refer the table below for LED status vs receiver's condition.

LED Indication

Green	Red	Status
Off	Solid	No signal reception
Solid	Off	Receiving signals
Alternate blink		Unrecoverable error (EEPROM, etc.)

Link to the transmitter

Easy Link ID allows FASSTest receivers to link to compatible transmitter without pressing the link button on the receiver.

- 1 Bring the transmitter and the receiver close to each other, within 20 inches (half meter).
- 2 Turn on the transmitter. Place the transmitter into the receiver linking mode.
- 3 Turn on the receiver.
- 4 The receiver will wait for the linking process to begin for 2 seconds. Following that it will return to the normal operation mode.
- 5 When the LED of the receiver changes from blinking red to solid green, linking is complete.
(A link waiting state is ended in 1 second.)

- Refer to the transmitters operation manual for complete details on how to place the transmitter into the linking mode.
- If there are many FASSTest systems turned on in close proximity, your receiver might have difficulty establishing a link to your transmitter. This is a rare occurrence. However, should another FASSTest transmitter/receiver be linking at the same time, your receiver could link to the wrong transmitter. This is very dangerous if you do not notice this situation. In order to avoid the problem, we strongly recommend you to double check whether your receiver is really under control by your transmitter.
- If the System Type of the transmitter is changed, the receiver will need to be re-linked to the transmitter.

Channel Modes

The R7008SB is capable of changing its channel allocations as described in the table below. This is especially important when using the receiver in a dual receiver mode. See your transmitter operation manual for complete details on operating in the dual receiver mode.

- 1 Press and hold down the Link/Mode button on the R7008SB receiver.
- 2 Turn the receiver on while holding down the Link/Mode button. After power up, the button can be released.
- 3 The LED should now be blinking red in one of the patterns described by the chart below.
- 4 Each press of the Mode/Link button advances the receiver to the next mode.
- 5 When you reach the mode that you wish to operate in, press and hold the Mode/Link button for more than 2 seconds.
- 6 Once locked into the correct mode the Red LED will change to a solid color.
- 7 Please cycle the receiver(s) power off and back on again after changing the Channel Mode.

R7008SB CH Mode table

Output connector	Channel			
	Mode A 1 ~ 8CH	Mode B 1 ~ 7CH	Mode C 9 ~ 16CH	Mode D 9 ~ 15CH
1	1	1	9	9
2	2	2	10	10
3	3	3	11	11
4	4	4	12	12
5	5	5	13	13
6	6	6	14	14
7/B	7	7	15	15
8/SB	8	S.BUS	16	S.BUS
Red LED blink	1 time	2 times	3 times	4 times

⚠ WARNING

- ⊘ Do not perform the linking procedure while the motor's main wire connected or the engine is operating as it may result in serious injury.
- ⚠ When the linking is complete, please cycle the receiver power and ensure the receiver is properly linked to the transmitter.
- ⚠ Please power up your system in this order. Transmitter first, followed by the receiver.
- ⚠ If the R7008SB receiver was previously linked to another transmitter, make sure that transmitter is not operating while linking the receiver to the new transmitter.

FASSTest

FASSTest is a bidirectional communication system between the R7008SB receiver and FASSTest capable transmitters. Multiple optional telemetry sensors may be connected to the **S.BUS2** on the receiver and that data is in turn displayed on the transmitter.

*Please see your transmitters operation manual to configure transmitter to operate with telemetry sensors.

S.BUS2

S.BUS2 extends **S.BUS** and supports bidirectional communication. Sensors are connected to the **S.BUS2** port.

*Only S.BUS2 capable devices may be connected to the S.BUS2 port. Standard S.BUS servos and gyros should not be connected to the S.BUS2 port.

What is S.BUS?

Unlike conventional radio control systems, the **S.BUS** system uses data communication to transmit control signals from a receiver to a servo, gyro, or other **S.BUS** compatible device. This data includes commands such as "move the channel 3 servo to 15 degrees, move the channel 5 servo to 30 degrees" to multiple devices. The **S.BUS** devices execute only those commands for their own set channel. For this reason, it can be used by connecting multiple servos to the same signal line.

- * Set the channel of **S.BUS** servos by using an **SBC-1** channel changer, **CIU-2** USB serial interface or the programming software resident in the **18MZ** transmitter.
- * Can also be used together with conventional servos. However, conventional servos cannot be used by the **S.BUS** output.
- * When using servos with a remote battery pack, use **S.BUS** Hub with Cable (2-way/remote battery pack use). Please refer to the instruction manual of **S.BUS** Hub with Cable (2-way/remote battery pack use) for the connection method.

[Connection by S.BUS system]

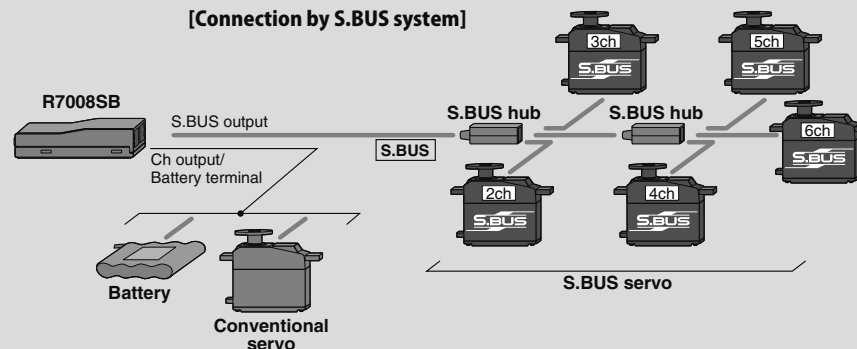

⚠ WARNING

- ⚠ Turn on the power in transmitter → receiver order. In addition, always check the operation of all the servos before flight.
- ⊘ Do not insert or remove the servo connector while the receiver power is ON.
Since the S.BUS servo switches the operation mode automatically according to the type of signal (S.BUS signal/PWM signal) from the receiver, if the connector is inserted or removed while the power is ON, an S.BUS connected servo will be erroneously recognized and may stop.

FUTABA CORPORATION

oak kandakajicho 8F 3-4 Kandakajicho, Chiyoda-ku, Tokyo 101-0045, Japan
TEL: +81-3-4316-4820, FAX: +81-3-4316-4823

©FUTABA CORPORATION 2018.5 (6)