

S-FHSS 2.4GHz System Receiver
S.BUS Port and RSSI
No Conventional System
For FPV drone / Small size model

Micro Receiver for FPV
R2000SBM

Applicable systems: Futaba
S-FHSS 2.4GHz system and
TM-FH RF Module

Thank you for purchasing the R2000SBM S-FHSS S.BUS receiver. This receiver is designed to be used with an FPV racing drone.

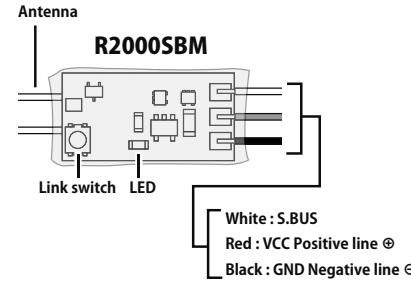

Compliance Information Statement (for U.S.A.)

This device, trade name Futaba Corporation, model number R2000SBM, complies with part15 of the FCC Rules. Operation is subject to the following two conditions:
 (1) This device may not cause harmful interference, and
 (2) This device must accept any interference received, including interference that may cause undesired operation.
 The responsible party of this device compliance is:
 FUTABA Corporation of America
 2681 Wall Triana Hwy Huntsville, AL 35824, U.S.A.
 Phone: 1-256-461-9399 FAX: 1-256-461-1059
 E-mail: service@futabaUSA.com

FEDERAL COMMUNICATIONS COMMISSION INTERFERENCE STATEMENT

This equipment has been tested and found to comply with the limits for a Class B digital device, pursuant to Part 15 of the FCC Rules. These limits are designed to provide reasonable protection against harmful interference in a residential installation. This equipment generates, uses and can radiate radio frequency energy and, if not installed and used in accordance with the instructions, may cause harmful interference to radio communications. However, there is no guarantee that interference will not occur in a particular installation. If this equipment does cause harmful interference to radio or television reception, which can be determined by turning the equipment off and on, the user is encouraged to try to correct the interference by one or more of the following measures:
 --Reorient or relocate the receiving antenna.
 --Increase the separation between the equipment and receiver.
 --Connect the equipment into an outlet on a circuit different from that to which the receiver is connected.
 --Consult the dealer or an experienced radio/TV technician for help.

Compliance Information Statement (for Canada)

CAN ICES-3(B)/NMB-3(B)

Compliance Information Statement (for EU)

Declaration of Conformity
 Hereby, Futaba Corporation declares that the radio equipment type R2000SBM is in compliance with Directive 2014/53/EU. The full text of the EU declaration of conformity is available at the following internet address:
<http://www.rc.futaba.co.jp/english/dl/declarations.html>

FUTABA CORPORATION
 oak kandakajicho 8F 3-4 Kandakajicho, Chiyoda-ku, Tokyo
 101-0045, Japan
 TEL: +81-3-4316-4820, FAX: +81-3-4316-4823
 ©FUTABA CORPORATION 2018, 11 (1)

CE

When using RSSI

When using the RSSI signal, it is necessary to be an aircraft (drone) equipped with OSD. RSSI information is outputted by S.BUS signal (16 CH). By connecting the S.BUS signal line to the flight controller and setting the OSD, you can display it on the FPV drone goggles and so on.
 *OSD is a function to set video display.

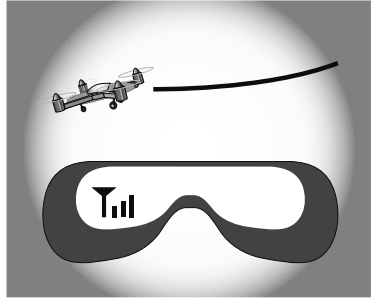

Link to the transmitter

Link to the transmitter

- 1 Bring the transmitter and the receiver close to each other, within 20 inches (half meter).
- 2 Turn on the transmitter.
- 3 Turn on the receiver.
- 4 Press and hold the **Link switch** more than two (2) seconds. When the link is complete, the LED in the receiver changes to **solid green**. When the ID cannot be read due to the surrounding environment, try reading it with the transmitter and receiver antennas touched.

• When you use TM-FH RF Module, the fail safe function can be set for channel 3 only.

• If there are many S-FHSS systems turned on in close proximity, your receiver might not link to your transmitter. In this case, even if the receiver's LED stays solid green, unfortunately the receiver might have established a link to one of the other transmitters. This is very dangerous if you do not notice this situation. In order to avoid the problem, we strongly recommend you to double check whether your receiver is really under control by your transmitter by giving the stick input and then checking the aircraft response.

Half meter

Link switch 2s

⚠ WARNING

⊘ Do not perform the linking procedure with the motor's main wire connected or the engine operating as it may result in serious injury.

Ⓛ When the linking is done, please cycle receiver power and check if the receiver to be linked is really under the control of the transmitter to be linked.

LED Indication

Green	Status
<i>Blink once</i> * * * * *	Receiving signals but ID is unmatched
<i>Solid</i> * * * * *	Receiving signals
<i>Blinks two</i> * * * * *	No signal reception
<i>Fast blink blink</i> * * * * *	Waiting for link

Connection example

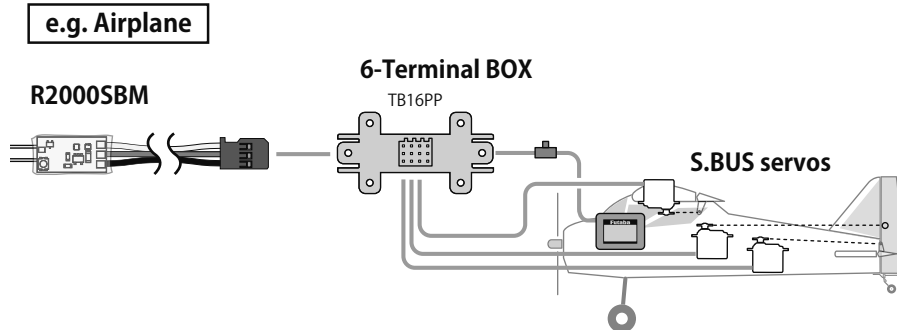
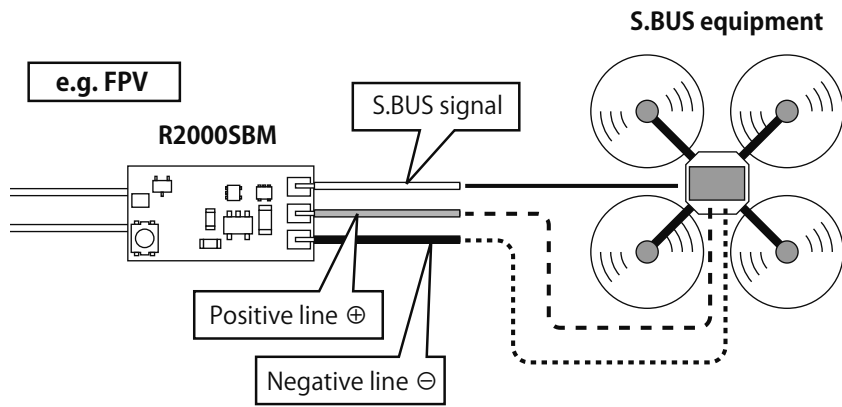

R2000SBM Specifications

S-FHSS 2.4 GHz system/S.BUS port and RSSI land

- Dual antenna diversity
- Size: 0.79 x 0.39 x 0.12 in. (20 x 10 x 3 mm)
- Weight: 0.1 oz. (2.9 g)
- Power requirement: 3.7 V to 8.4 V
- Battery F/S Voltage: 3.8 V

*Be sure that when using ESC's regulated output the current capacity of the ESC meets your usage condition.

*The Battery F/S voltage is set for 4-cell NiCd/NiMH battery. Battery F/S function doesn't work properly when a different type of battery is used.

*The fail safe function can be set for each channel. However, it differs according to the transmitter. When you use TM-FH RF Module, the fail safe function can be set for channel 3 only.

*S.BUS port: R2000SBM can be used with up to 8 channels. However, it differs according to the transmitter. An unused channel is a neutral signal. The F/S setting channel at F/S is F/S position. Another, it is Hold signal.

Usage precaution

• Futaba S-FHSS system does not work with current Futaba FASST/FASSTest/T-FHSS system. Futaba FASST/FASSTest/T-FHSS system and S-FHSS system are not compatible with each other.

- ❗ Changes or modification not expressly approved by the party responsible for compliance could void the user's authority to operate the equipment.
- ❗ The R2000SBM receiver should be protected from vibration by foam rubber, hook and loop tape, or similar mounting methods. Protect from moisture.
- ❗ Keep away from conductive materials to avoid short circuits.
 - Doing so may cause erroneous operation.
- ⚠ Do not expose the receiver to high temperatures.
 - The shrink cover could become distorted.
- ⚠ Do not break the tube.
 - Could cause a short circuit.
- ❗ Be aware of static electricity.
 - There is a danger of malfunction or damage due to static electricity.

Antenna installation precaution

- ⚠ Do not cut or bundle the receiver antenna wire.
- ⚠ Do not bend the coaxial cable. It causes damage.
- ❗ The antenna should not be pulled.
- ❗ Keep the antenna as far away from the motor, ESC and other noise sources as you possibly can.
- ⚠ Do not touch the antenna to metal, carbon, or other conductive material.
- ❗ Be sure that the two antennas are placed at 90 degrees to each other.
 - The R2000SBM has two antennas. In order to maximize signal reception and promote safe modeling Futaba has adopted a diversity antenna system. This allows the receiver to obtain RF signals on both antennas and fly problem-free.

Antenna installation for carbon fuse

- ❗ The antenna portion of 30mm tip must be fully exposed.
 - Please make sure that the exposed portion won't slide back in the fuse due to wind pressure or other force during the flight session.

(Antenna installation)

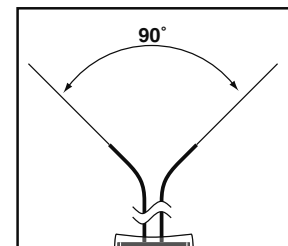

S.BUS

What is S.BUS?

Different from conventional radio control systems, the S.BUS system uses data communication to transmit control signals from a receiver to a servo, gyro, or other S.BUS compatible devices. This data includes commands such as "move the channel 3 servo to 15 degrees, move the channel 5 servo to 30 degrees" to multiple devices. The S.BUS devices execute only those commands for their own set channel. For this reason, it can be used by connecting multiple servos to the same signal line.